

MODEL 404

Liquid Level Sensor

- Digital display of water depth
- Solid-state outputs
- Four adjustable trip points
- 4-20mA output
- Moisture protected circuits

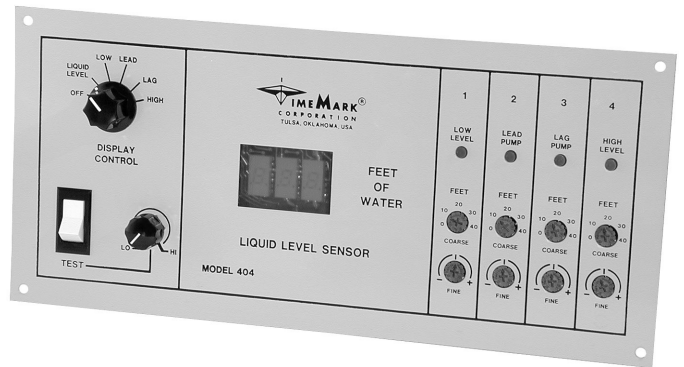

DESCRIPTION

The Model 404 Liquid Level Sensor operates in conjunction with a Model 403 Controller for bubbler-type duplex pumping systems. The 404 contains an air pressure-to-voltage transducer and requires only a small compressor capable of 15 psi (pounds per square inch) to operate the system down to approximately 35 feet.

The Model 404's four outputs are designed to replace the float switch inputs to a Model 403, or to be used with a Model 448 Output Relay Board. A 4-20mA signal output provides for other control applications.

A 3-digit LED display continuously shows the liquid level to a tenth of a foot when the Display Control switch is in the Liquid Level position. Other settings of the switch allow setting of the liquid level trip points. LED Indicators illuminate as the levels are exceeded. A test control allows the trip settings to be checked without actually raising or lowering the liquid level.

SPECIFICATIONS

MODEL	404-24V	404-115V
Input voltage	20-28VAC	105-130VAC
Input frequency	47-65Hz	
Power consumption	2W	
Air pressure input	0-15 psi max.	
Input air supply fitting	Requires 3/16" I.D. tubing	
Maximum liquid level displayed	34.6 feet	
Calibration accuracy	± 2%	
Repeat accuracy (fixed condition)	± 1%	
Repeat accuracy (0-60° C)	± 2%	
Dead band	0.1 foot	
Switching outputs	4 open-collector transistors rated for regulated 12VDC, 10mA, maximum. Designed as inputs for the Model 403 Liquid Level Controller or Model 448 Output Relay Board	
Signal outputs	4-20mA output proportional to 0-34.6 feet of water	
Operating temperature	- 20° to +122° F	
Storage temperature	- 4° to +158° F	
Humidity tolerance	0-97% without condensation	
Case material	20 gauge Steel	
Termination	Removable terminal strip	
Weight	3.5 lbs	

DIMENSIONS

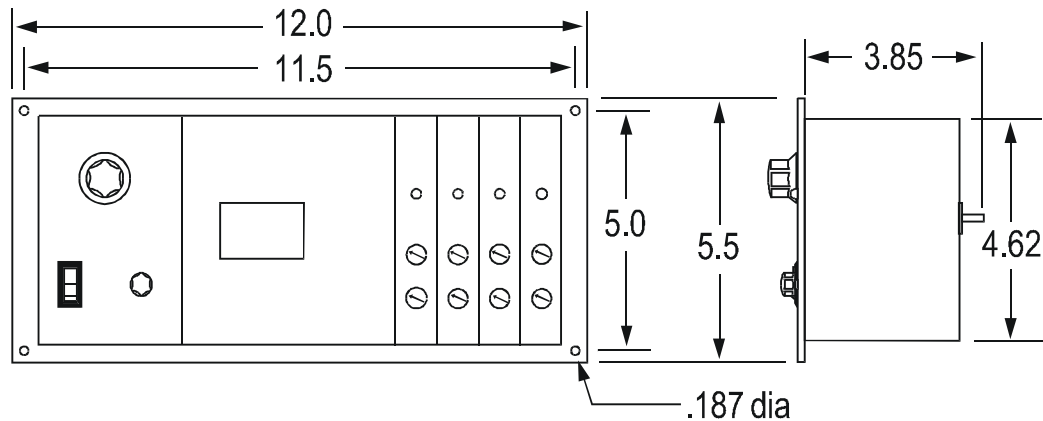

TIME MARK
CORPORATION

MODEL 404

Liquid Level Sensor

READ ALL INSTRUCTIONS BEFORE INSTALLING, OPERATING OR SERVICING THIS DEVICE.
KEEP THIS DATA SHEET FOR FUTURE REFERENCE.

GENERAL SAFETY

POTENTIALLY HAZARDOUS VOLTAGES ARE PRESENT AT THE TERMINALS OF THE MODEL 404.
ALL ELECTRICAL POWER SHOULD BE REMOVED WHEN CONNECTING OR DISCONNECTING WIRING.
DO NOT EXCEED THE OUTPUT OR INPUT RATINGS, AS STATED IN THE SPECIFICATIONS.
PROTECT THE UNIT WITH PROPERLY RATED FUSES.
DO NOT INSTALL IN DAMP OR MOIST AREAS.

THIS DEVICE SHOULD BE INSTALLED AND SERVICED BY QUALIFIED PERSONNEL.

Installation Instructions

INSTALLATION

Mount the Sensor in a suitable enclosure. If a Model 448 relay module is being used, mount it in a suitable location near the Sensor.

Referring to the terminal block decal on the sensor and the illustration on this page, make the following connections

1. Connect a chassis ground to the terminals marked CHS GND.
2. Connect operating power (24 or 120VAC) to the terminals marked for input voltage.
3. Observing polarity, connect the LOW terminals to the LOW terminals on the 403. For connections to 448, refer to connection chart on page 4.
4. Repeat step 3 for the LEAD, LAG, and HIGH terminals.
5. The terminals marked LIQUID LEVEL are the 4-20mA output. If used, connect these terminals to the appropriate control circuitry. Observe polarity.

Connect a 3/16" I.D. tubing to the air supply fitting on the back of the 404. Connect the other end of the tubing to the air compressor and the tank or well. Apply operating power and proceed to the adjustment procedure.

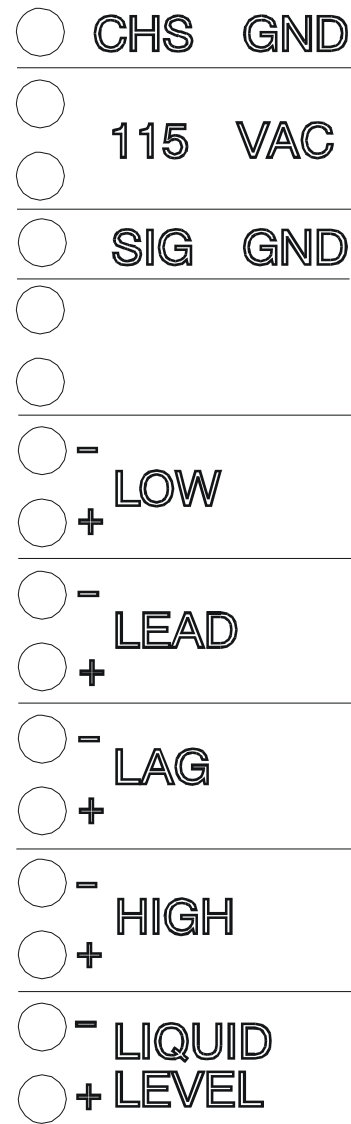

TIME MARK
CORPORATION

Model 404 Panel

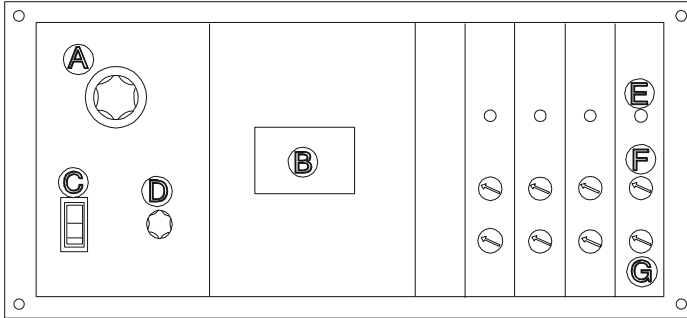

PANEL LAYOUT

- A. Display control switch used to select liquid level or level setting.
- B. 3-Digit LED indicator reads depth in feet.
- C. Test switch enables simulated level change by rotating control D.
- D. Simulates liquid level change when switch C is pressed.
- E. Indicator LED shows when level is reached (one per level)
- F. Coarse adjustment for setting level trip point (one per level)
- G. Fine adjustment for setting level trip point (one per level)

ADJUSTMENT

1. The trip points are set using coarse and fine adjustment pots; the results are shown on the LED display. To adjust the device, set the display control knob (A) to LOW and adjust the low level coarse adjustment (F) to the approximate desired level. A fine adjustment (G) is located below the coarse adjustment. The trip level will be shown on the LED display (B).
2. Repeat step 1 for the lead, lag and high level adjustments.
3. Set the display control knob to the LIQUID LEVEL position. The Sensor is now ready to operate.

TESTING

For testing purposes a test switch (C) and LO_HI adjustment (D) are provided. Set the adjustment to LO, then press and hold the test switch. As the adjustment is turned clockwise (HI), the LED display will show an increasing simulated liquid depth. As each level is reached the appropriate LED indicator (E) will illuminate and the output should activate (pump will turn on, output relay will energize, or alarm will sound).

TROUBLESHOOTING

- Problem:** Erratic and/or unstable operation when used with 403.
- Cause:** Signal ground wire between the two units is not connected.
- Solution:** Connect signal ground.
- Problem:** In test position, display reads other than zero with adjustment fully counterclockwise
- Cause:** This is a normal condition; fully counterclockwise on the adjustment may be below zero.
- Solution:** Turn the adjustment slightly clockwise; the display should read zero (or higher).

Note: This device is not a field repairable unit. Should the unit not operate properly during installation or testing, insure that all electrical, ground, and physical connections are correct. Verify that the proper voltage is applied and check all fuses. Contact the factory if everything is correct and the device still fails to operate. Should the sensor fail during use, contact the factory for instructions on returning the device for repair.

WARRANTY

This product is warranted to be free from defects in materials and workmanship for one year. Should this device fail to operate, we will repair it for one year from the date of manufacture. For complete warranty details, see the *Terms and Conditions of Sales* page in the front section of the Time Mark catalog or contact Time Mark at 1-800-862-2875.



MODEL 404

Liquid Level Sensor

TYPICAL APPLICATIONS

Model 404 to Model 403

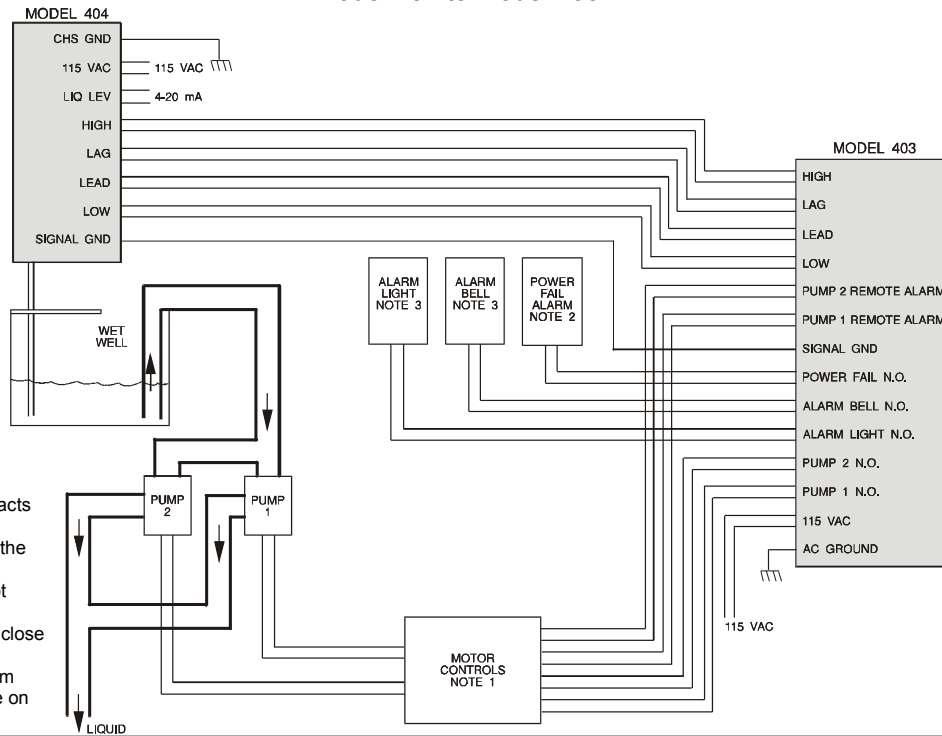

Note:

1. Remote alarm contacts are normally closed contacts located at the motor controllers. Jumper closed if not used.
2. Power fail contacts close on power failure.
3. Alarm Bell and Alarm Light contacts close on alarm condition.

Model 404 to Model 448

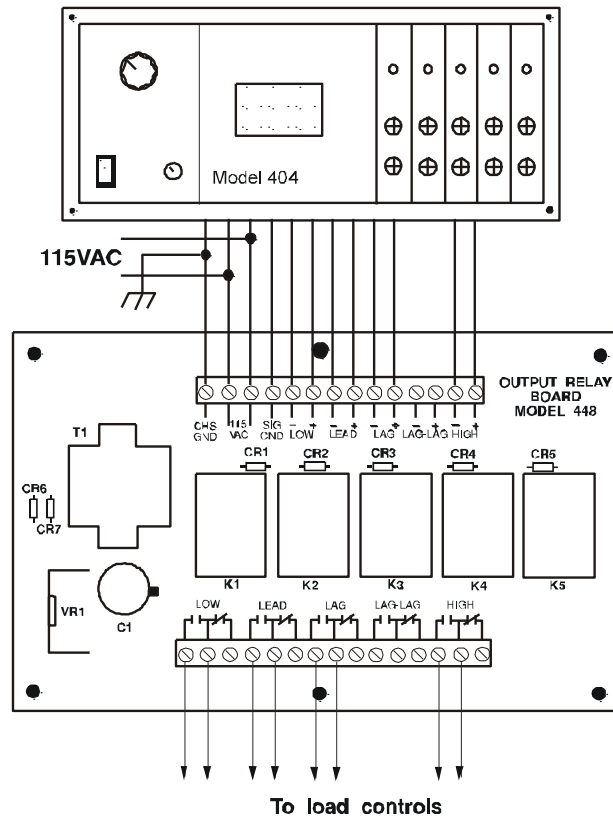

TIME MARK
CORPORATION